

# ALP TEX

## Probes For Fine Pitch Connections

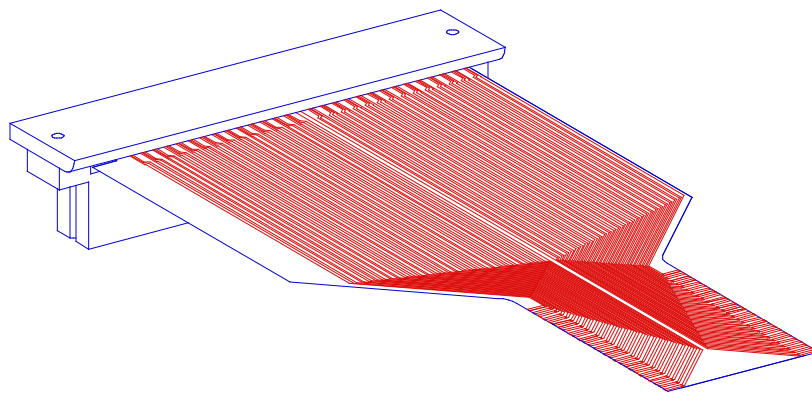

SSOP FlexProbes  
0,8mm (.0315") Pitch

# SSOP FlexProbes 0,8mm (.0315") Pitch

## Data/Application Sheets

ALPTEX  
Part Number

Description

---

923725

Standard Pinout, Socket Connector,  
Direct Solder Type, 56 Lead

---

.pdf files are also available for the following:

- 0,50mm (.0197") Pitch TSOP FlexProbes...TSOP\_FP.pdf
- 1,27mm (.050") Pitch PSOP FlexProbes...PSOP\_FP.pdf
- 1,27mm (.050") Pitch PLCC FlexProbes...PLCC\_FP.pdf
- 0,75mm (.0295") Pitch microBGA FlexProbes...mBGA\_FP.pdf
- FlexProbe Extenders...EXTENDFP.pdf

# SSOP FlexProbe (Direct Solder)

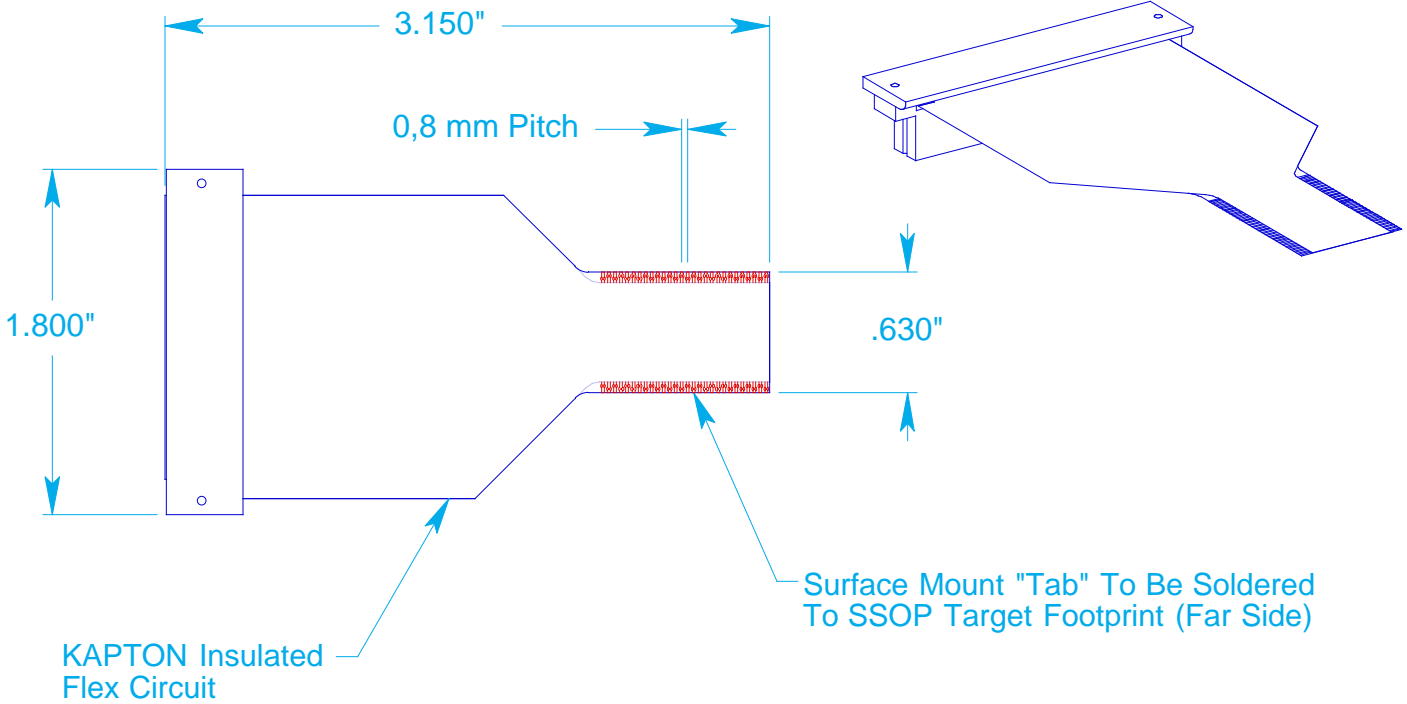

|                |                |                    |
|----------------|----------------|--------------------|
|                |                | <b>ALPTX</b>       |
| <b>PACKAGE</b> | <b># LEADS</b> | <b>PART NUMBER</b> |
| SSOP           | 56             | 923725-56          |

## FEATURES:

- THE MOST FLEXIBLE "TARGET" INTERCONNECT AVAILABLE...MINIMIZES PHYSICAL STRAIN ON THE TARGET PADS.
- A UNIQUE SOLUTION FOR CONNECTING DIRECTLY TO YOUR P. C. BOARD.
- REFLOW SOLDERS TO STANDARD SSOP PAD PATTERN.
- ELIMINATES NEED TO ALTER P. C. BOARD BETWEEN DEVELOPMENT AND PRODUCTION PHASES.
- COMPACT LENGTH VIRTUALLY ELIMINATES CROSSTALK / EMI PROBLEMS.
- MADE ENTIRELY IN THE U.S.A.
- FLEXPROBES FOR EMULATING OTHER POPULAR COMPONENT PACKAGES ARE ALSO AVAILABLE...CONSULT FACTORY.

ALL STATEMENTS, SPECIFICATIONS AND TECHNICAL INFORMATION ON THIS DATA SHEET ARE SUBJECT TO CHANGE AT ANY TIME WITHOUT NOTICE.

**ALPTX** Incorporated  
P.O. Box 476  
Orwell, Ohio 44076  
(440)437-5570 • (440)437-5571 FAX  
[www.alptex.com](http://www.alptex.com)

# SSOP FlexProbe Application Data

ALPTEX Part Number 923725-56  
(Direct Solder)

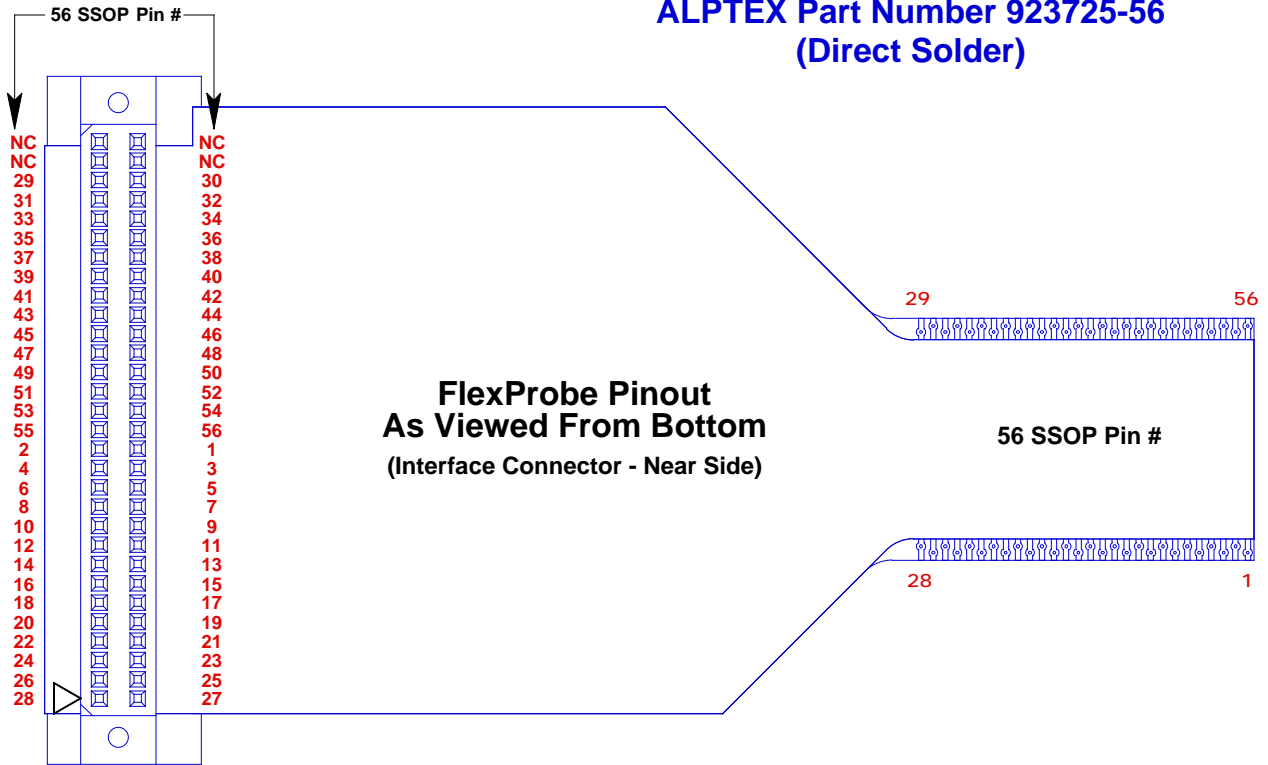

**Note:** This FlexProbe is designed to be reflow soldered directly to the P. C. Board. It is not intended for use with sockets.

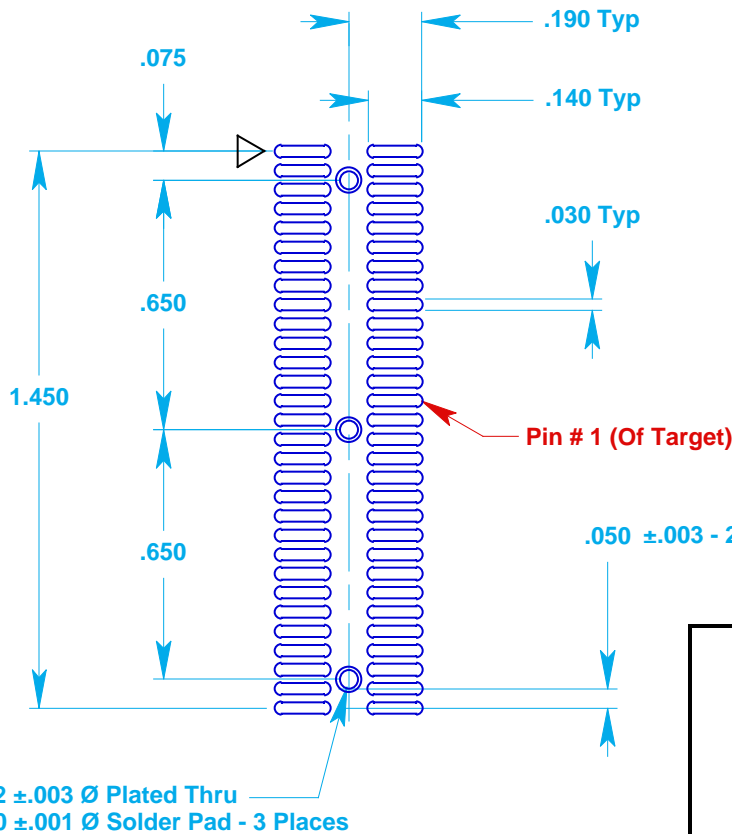

**P C Board Pad Pattern  
For Mating AMP Connector  
AMP #104549-8**  
(Solder Pads - Near Side)

**ALP  
TEX** Incorporated  
P.O. Box 476  
Orwell, Ohio 44076  
(440)437-5570 • (440)437-5571 FAX  
[www.alptex.com](http://www.alptex.com)

ALL STATEMENTS, SPECIFICATIONS AND TECHNICAL INFORMATION ON THIS DATA SHEET ARE SUBJECT TO CHANGE AT ANY TIME WITHOUT NOTICE.